

EASY Reach

FRP Access System



Global Composite Village™



An Overview

The foundation of **Kemrock** was laid in 1981 with a vision to establish Global Composites Village™ subsequently achieving the dream of having single point station for all composite solutions. **Kemrock** caters to the complete portfolio of composite products offering application specific customized solutions to a wide range of industrial sector.

At **Kemrock**, the concepts are converted into realities and monitored until commissioning by highly skilled professionals. The principals of integrated management to ensure ultimate customer satisfaction are adhered to, religiously at **Kemrock**. The complete range of advanced composite products renders high-quality engineered FRP solutions to all applications & multiple areas.



Why Kemrock - EasyReach FRP Access System?

Falls from height in the workplace are the most common cause of fatal injury to workmen. All industry sectors are vulnerable to the risks presented by the hazard.

It is impossible to overlook this aspect of fatal and major injuries which has now assumed a key priority in Health & Safety norms of every industry. The paramount object of every industry is to reduce injury rate. The safety equipment to work at heights is ofcourse ladders, and if that is modernized to suit present day working hazards, the automatic choice is Scaffolding.

What is Kemrock - EasyReach FRP Access System?

Access System is a temporary platform constructed for performing work or reaching heights above arms' reach for activities relating to building construction, maintenance, or repair. Access System is conventionally made of lumber or steel, however **Kemrock** replaces these conventional materials with Fibre Reinforced Plastic (FRP), with the ease of handling, safety and longer life.

Benefits of Kemrock - EasyReach FRP Access Systems

- Corrosion Resistant
- Light Weight
- Easy Assembling & Dismantling
- Narrow width allows easier access into smaller or awkward areas
- Range of heights available
- Instant assembly with fold-out frame
- Safety features such as locking castors included as standard
- Easily folds for transport and efficient storage
- Non conductive
- Non sparking
- Non oxidising
- Clean
- Comfortable to handle in both very cold and warm climates





Features of Kemrock - EasyReach FRP Access System

- Manufactured using tube with an additional circumferential winding for increased compressive and flexural strength (up to 4 times greater than other GRP tower systems)
 - High visibility due to vibrant color
 - Impact resistant claws
 - Integral ladders with 250mm easy climb rung spacing
 - 500mm frame rung spacing in compliance with Work at Height Regulations
 - Ribbed rung tubing for increased grip
 - 3T – Through the Trap build method
 - Two widths – 850mm Single Width and 1450mm Double Width
 - 2 slip resistant platform lengths – 1.9 and 2.5m with self closing trapdoors and windlocks
 - The maximum platform safe working load is 225kg
 - Primed brace claw mechanism
 - Ease of brace identification:
 - ◆ Red – horizontal
 - ◆ Blue – diagonal
 - Horizontal braces used as guardrails
 - Self cleaning adjustable legs
 - Castors with compact trail/no trail positive locking brake mechanism
 - Deck board edge protection provided by profile of GRP deck
 - Easy to use toe-board system
 - No scrap value leading to increased security on site
- Lift shaft/confined space stabiliser available

ACCESS TOWER

Double Width Tower

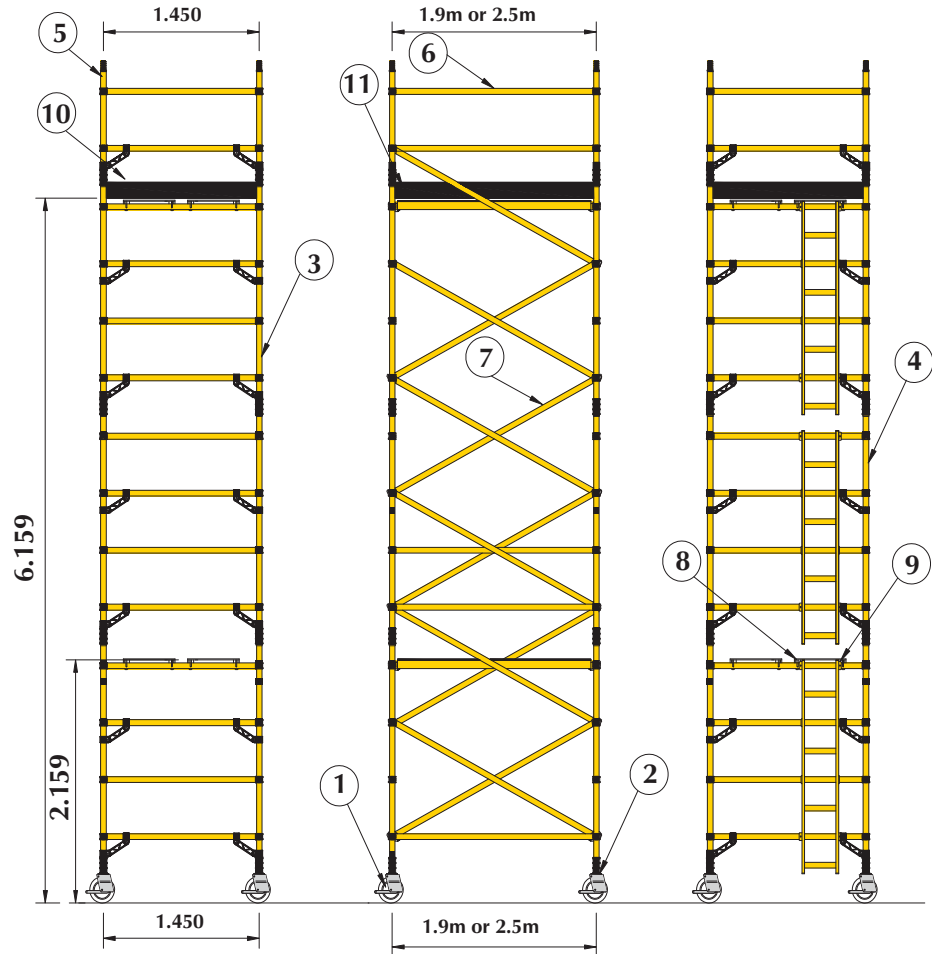

Single Width Tower

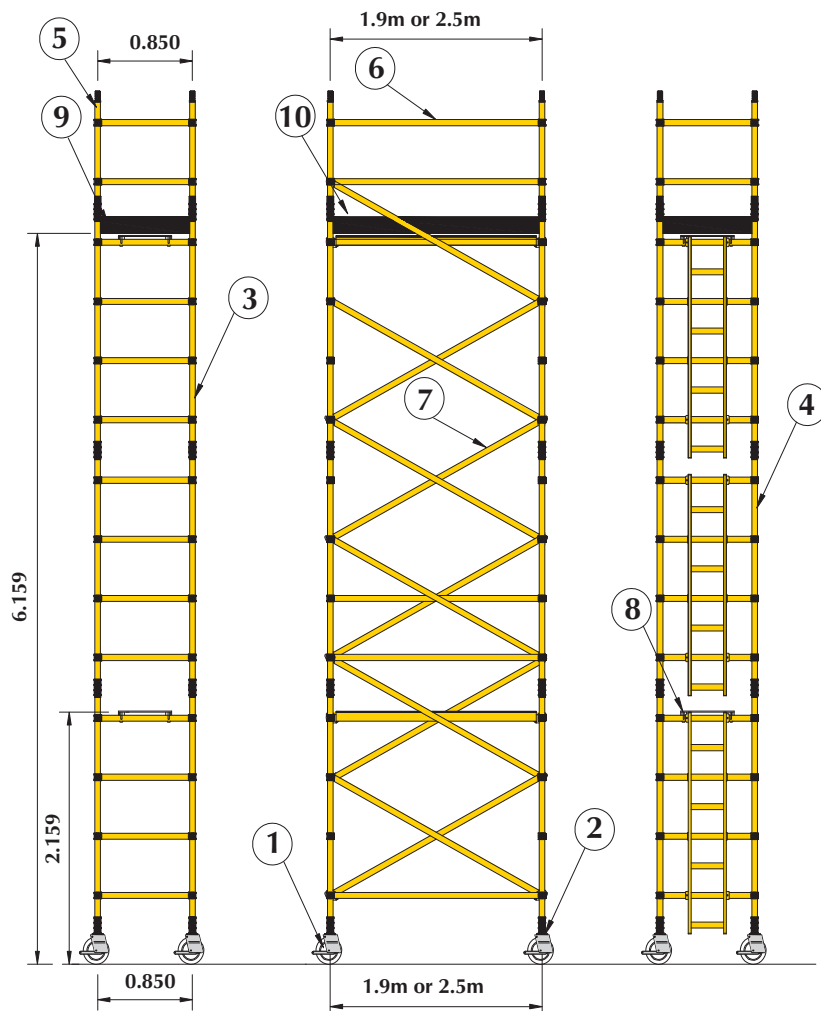

SPAN FRAME

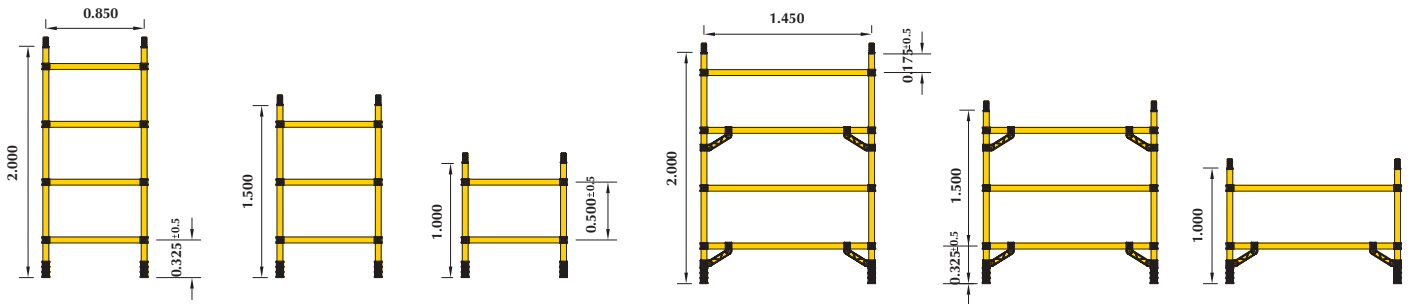

Specification	Frame Rung Pitch :- all 500mm, Tube Diameter :- all 50.8mm Span Rung Pitch :- all 250mm		
	0.85m Span Frame		
Part Code No.	Description	Width	Height
COATSF0851	1.0m 2-Rung Span Frame	0.85m	1.00m
COATSF0852	1.5m 3-Rung Span Frame	0.85m	1.50m
COATSF0853	2.0m 4-Rung Span Frame	0.85m	2.00m
	1.45m Span Frame		
Part Code No.	Description	Width	Height
COATSF1451	1.0m 2-Rung Span Frame	1.45m	1.00m
COATSF1452	1.5m 3-Rung Span Frame	1.45m	1.50m
COATSF1453	2.0m 4-Rung Span Frame	1.45m	2.00m

LADDER FRAME

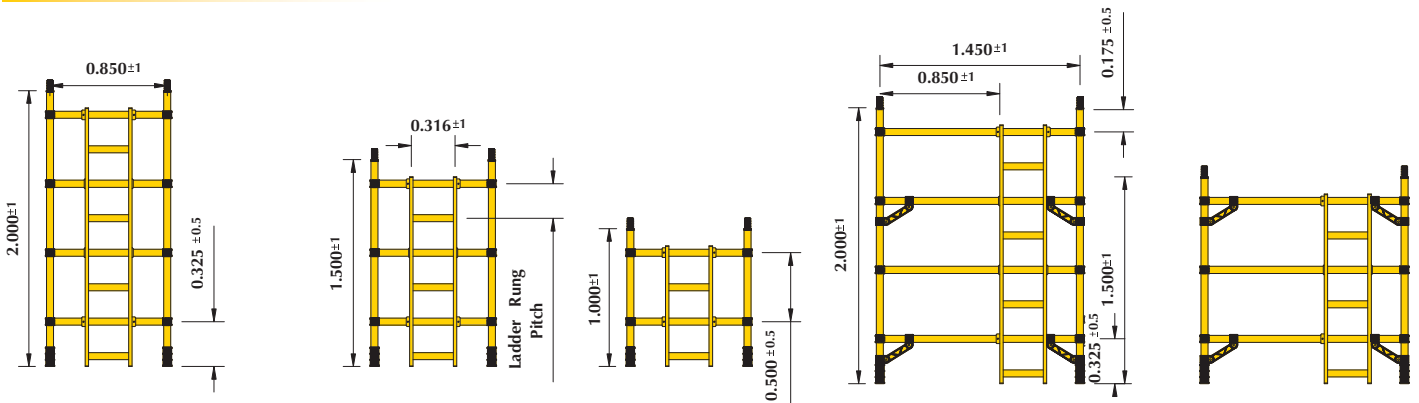

Specification	Frame Rung Pitch :- all 500mm, Tube Diameter :- all 50.8mm Ladder Rung Pitch :- all 250mm		
	0.85m Ladder Frame		
Part Code No.	Description	Width	Height
COATLF0854	1.0m 2-Rung Ladder Frame	0.85m	1.00m
COATLF0855	1.5m 3-Rung Ladder Frame	0.85m	1.50m
COATLF0856	2.0m 4-Rung Ladder Frame	0.85m	2.00m
	1.45m Ladder Frame		
Part Code No.	Description	Width	Height
COATLF1454	1.0m 2-Rung Ladder Frame	1.45m	1.00m
COATLF1455	1.5m 3-Rung Ladder Frame	1.45m	1.50m
COATLF1456	2.0m 4-Rung Ladder Frame	1.45m	2.00m

FIXED DECK

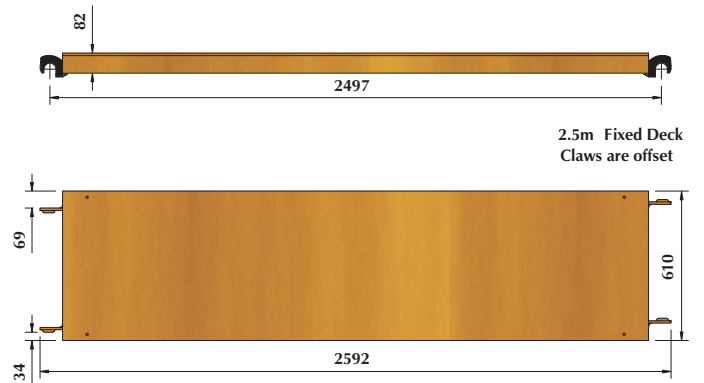
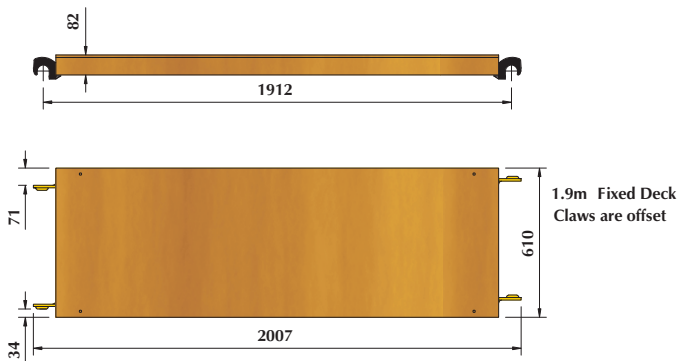

Specification	All Plywood 12mm thick with non-slip surface
Part Code No.	Description
COATFD1219	1.9m Fixed Deck
COATFD1225	2.5m Fixed Deck
COATET1215	End Toeboard - 1.5m
COATET1209	End Toeboard - 0.9m
COATST1219	Side Toeboard - 1.9m
COATST1225	Side Toeboard - 2.5m

TRAPE DOOR DECK

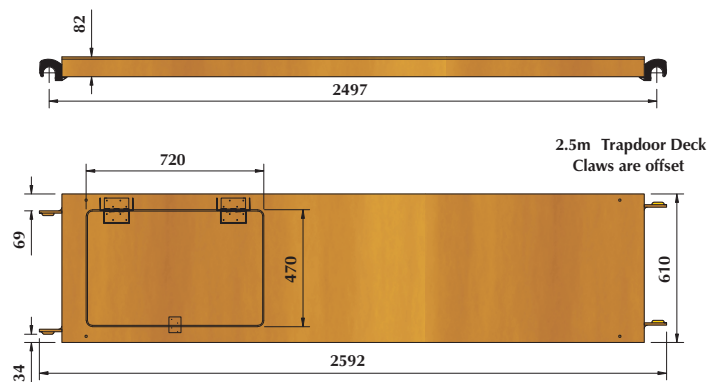
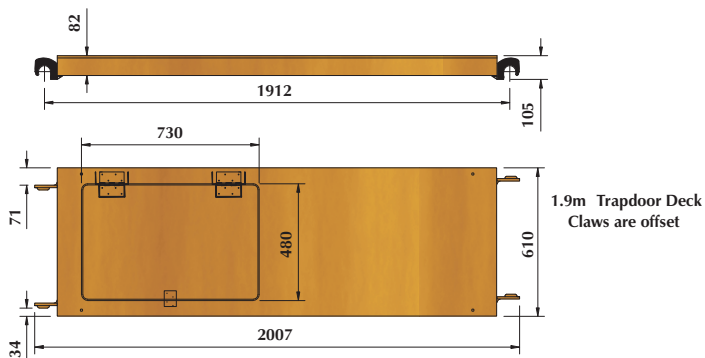

Specification	All Plywood 12mm thick with non-slip surface
Part Code No.	Description
COATTD1219	1.9m Fixed Deck
COATTD1225	2.5m Fixed Deck

BRACE

Specification	Component	Dimension
Part Code No.	Component	Dimension
COATHB1901	Horizontal Brace	1.9m
COATHB2502	Horizontal Brace	2.5m
COATDB2203	Diagonal Brace	2.2m
COATDB2704	Diagonal Brace	2.7m

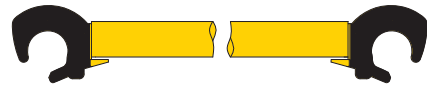

ACCESSORIES

Specification	Component	Dimension
Part Code No.	Component	Dimension
COATAL6001	Adjustable Leg	0.68m
COATCR0824	200mm (8") Castor	0.24m
COATCR0619	150mm (6") Castor	0.19m
COATCR0516	125mm (5") Castor	0.16m
COATSB1501	Swivel base Plate	0.15m
COATLS2190	Large Stabilizer	1.79m x 2.19m
COATSS1730	Standard Stabilizer	1.41m x 1.73m

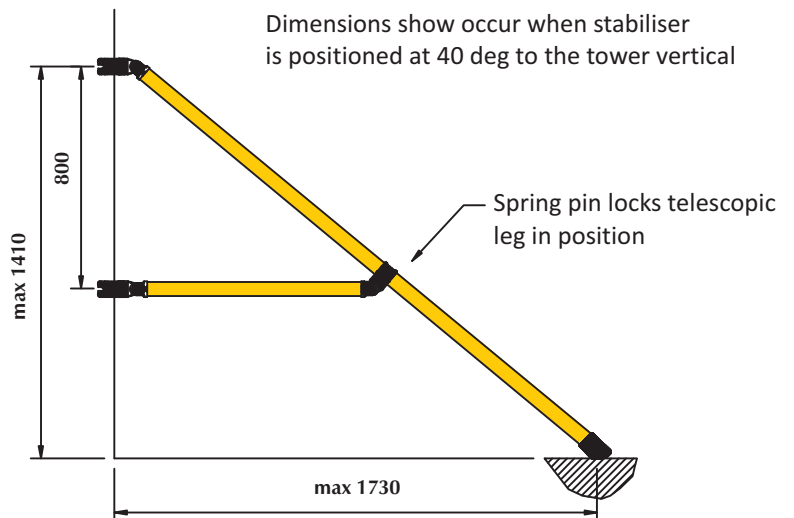
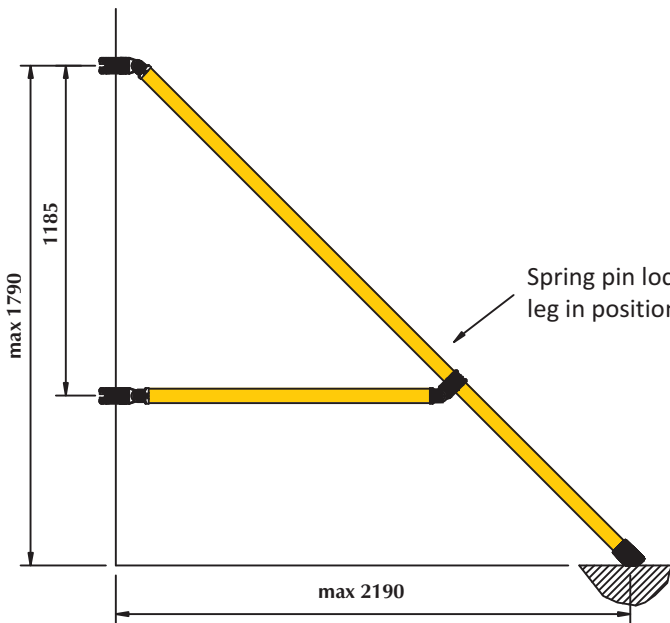

Adjustable Leg

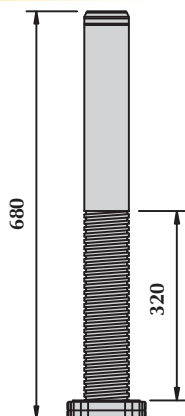

Swivel Base

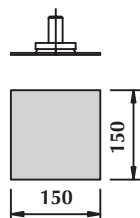

Castor

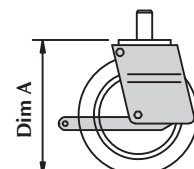

Assembly Procedure



1 Push castor onto adjustable leg to secure. Insert 2 adjustable leg/castor assemblies into span frame. Base plates can be fitted to adjustable legs if it is not necessary to move the tower.

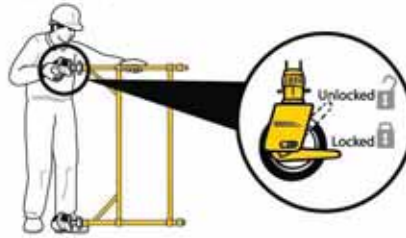

2 Fit one horizontal brace (red) onto the vertical of the span frame, just above the bottom rung, with the claw facing outwards. The frame will now be self-supporting.

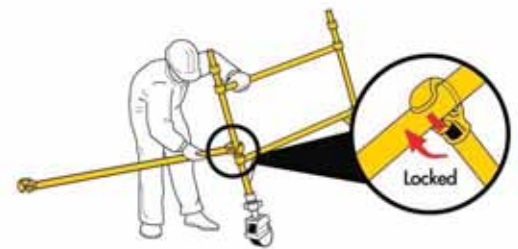

3 Position the ladder frame as shown and fit the other end of the horizontal brace onto the vertical, just above the bottom rung. Fit a second horizontal brace between the bottom rungs on the other side of the frames to square the tower.

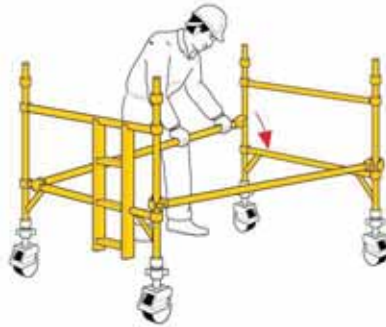

4 Fit 2 additional end frames and check the frame interlock clips are engaged. Fit 2 diagonal braces in opposing directions between the 1st and 3rd rungs. Ensure the frames are vertical and level by checking with a spirit level and setting the adjustable legs as required. **IMPORTANT:** Only use the adjustable legs to level the tower and not to gain extra height. Fit a temporary fixed deck on the lowest rungs of the tower. Fit the stabilisers.



5 Fit 2 more diagonals in opposite directions between the 3rd and 5th rungs of the tower. Fit a trapdoor deck on the 4th rungs of the tower with the trapdoor next to the ladder and opening towards the outside of the tower. Climb the ladder and, from the protected trapdoor position, fit horizontal braces as guardrails on the 5th and 6th rungs, on both sides of the tower. **NEVER** climb on to the platform until it is fully guardrailed. Guardrails should be 0.5m and 1.0m (1 and 2 rungs) above the platform in all cases. Remove the temporary deck from the lowest rungs of the tower.



6 Add 2 more frames. Ensure ladders are always positioned one above the other.

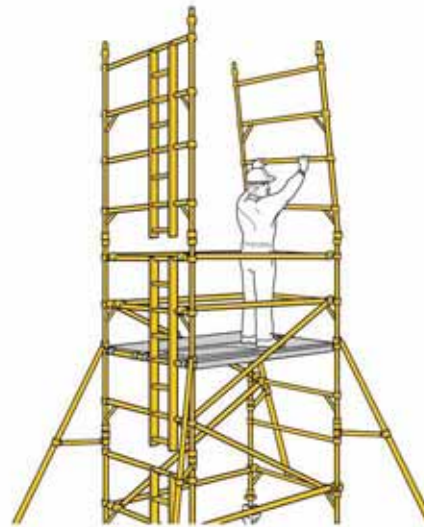

7 Fit 2 more diagonals between the 5th and 7th rungs. Fit a trapdoor deck on the 8th rungs of the tower. Fit a fixed deck next to it.

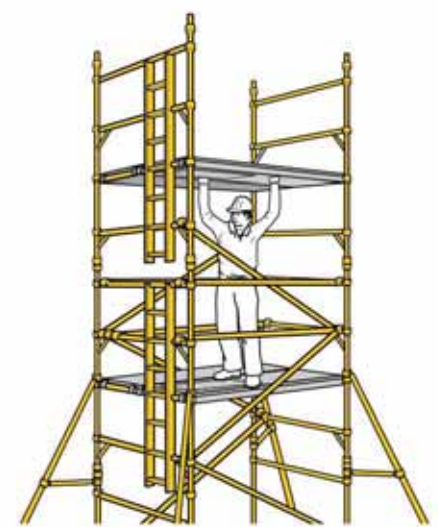

8 Fit 2 more diagonals between the 7th and 9th rungs. Climb the ladder and from the protected trapdoor position, fit 4 more guardrails on the 9th and 10th rungs.

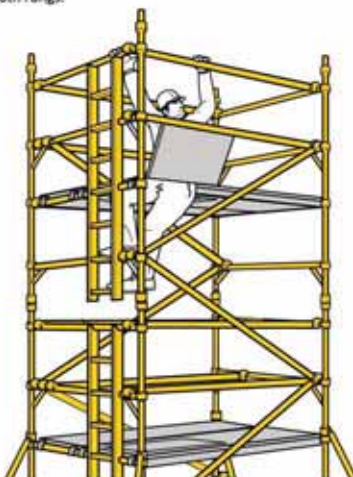

9 Repeat the previous steps until the required height of tower is reached. Fit the toeboards. The tower is now complete.

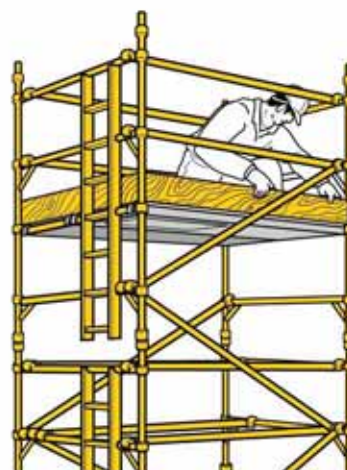

Dismantling Procedure

To take down the tower reverse the building sequence. When removing guardrail braces, unlock the 4 claws furthest from the trapdoor and then return immediately to the protected position within the trapdoor. You may then unlock the claws at the other ends of the guardrails to remove them from the tower.

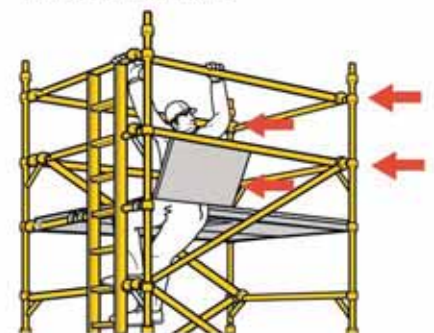

Other Products

- Phenolic, Unsaturated Polyesters & Epoxy Resins
- GRP Piping System
- Moulded, Pultruded & Phenolic Gratings
- Pultruded Structural Profiles
- Windmill Blades, Nacelle Covers & Nose Cones
- Carbon Fibre
- Rail Coach Interiors & Exteriors
- Industrial Cable Management System
- Handrails & Ladders
- SMC Doors

Pultruded Shapes

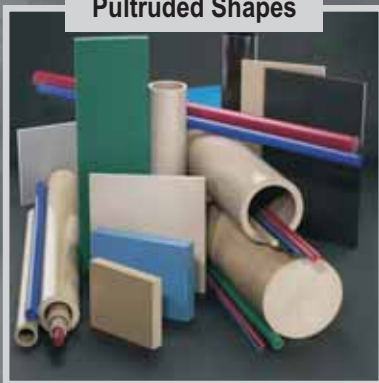

Gratings



Cable Trays



Piping Systems

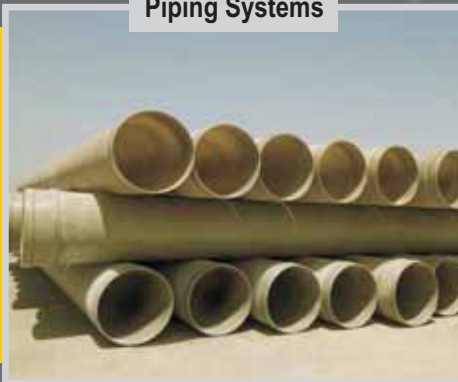

Poles



Rail Exteriors

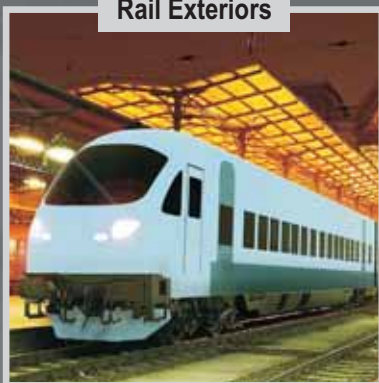

Rail Interiors



Wind Energy

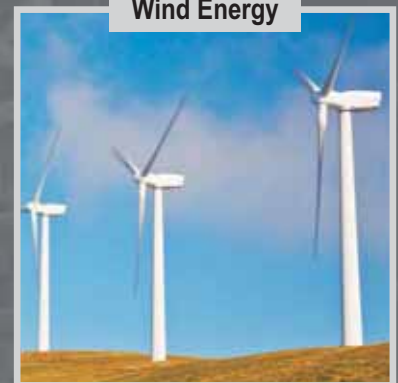



ISO 9001:2008 / ISO 14001:2004 / OHSAS 18001:2007

EASY Reach
FRP Access System

Manufactured by:



www.kemrock.com

Regd. Off.: Village Asoj, Vadodara-Halol Express Way, Tal. Waghodia, Dist. Vadodara-391 510, Gujarat, INDIA
Phone: +91-2668-666200 | **Fax:** +91-2668-666400
Cell: +91-9558810744, +91-9558810944
E-mail: sales@kemrock.com, info@kemrock.com