

1. Installation & Maintenance of Motors**► Receiving and storing of motors :**

- ❖ Make sure that the right type of motor as ordered by you has arrived and it is not damaged in transit. In case of any such problem report immediately to our office.
- ❖ Store the motor in a clean dry place if it is not to be installed immediately.

► Installation and mounting of motors :

Before installation and mounting observe the following.

- ❖ See that the motor rotates freely by turning the shaft by hand.
- ❖ Replace the grease charge of bearings if the motor has been stored for longer than 18 months.
- ❖ Check the insulation resistance by applying a D. C, voltage of 500 V. If it is low due to moisture, dry out the stator winding till the insulation resistance increases above one megaohm by any of the accepted methods. (Ref. IS 900- 1992)
- ❖ Remove anticorrosion coating on the shaft with petrol, white spirit or kerosene. Do not scrape the coating.
- ❖ See that the machined surface of motor feet (or flange face) and also the surface on which the motor is mounted is clean and perfectly in level.
- ❖ The coupling parts to be fitted on the motor shaft are to be properly balanced. The bore and key way are to be machined accurately. The recommended tolerance for the bore diameter is H7.
- ❖ The coupling parts or pulley must be carefully fitted by means of special tackle for which a tapped hole is provided at shaft end. Hammering must be avoided since it might damage bearings. The tackle can also be used for removal of coupling (See Fig.1)
- ❖ While using Non-flexible coupling it should be noted the shafts of the motor and the driven machine must be in perfect alignment and axes should coincide. Inaccurate alignment results in stresses on bearings and noisy running.
- ❖ See that screws for fixing the motor (or flange) to the foundation, are secured properly.
- ❖ Install the motor such that the cooling air has free access and can pass unobstructed over the motor.

► Electrical Connections :

While doing electrical connection ensure following points:

- ❖ Use appropriate size of cable for connecting the motor.
- ❖ The supply voltage should be same as given in the rating plate. Unless otherwise specified the tolerances is 10% of the rated voltage.
- ❖ Connect the motor in accordance with the connection (Star or Delta) given in the rated plate and connection diagram given inside the Terminal box cover.
- ❖ **Connect earth terminal effectively for protection. This is very important to ensure safety. Local electrical code must be followed.**
- ❖ Normally 3 phase motors upto 2 HP have their winding connected in Star (Y). These motors have three terminals and are meant for direct on line starting only.
- ❖ Motors above 2 HP have windings suitable for delta (D) connection. These motors can be started with a Y-D starter or Direct on Line starter using connecting links as shown in the connection diagram.
- ❖ While connecting the cables to motor terminals please ensure that the cable is properly secured and clamped and it does not exert any tension on terminal. A heavy load or tension by the cable can break the terminals.
- ❖ **Motors must be installed as per the local electrical code/regulation by an authorised person. Motors must be protected against overload and short circuit conditions.**

► Maintenance :

During maintenance please note the following points :

- ❖ The bearings are prelubricated and maintenance free. Operating conditions permitting, unsealed bearings should be cleaned at intervals of about 10000 operating hours, with trichloroethylene or clean petrol. While lubricating please see that the bearings are well lubricated and

about one third of the space within bearing covers is filled with grease. Over filling of grease is not recommended.

While regreasing motors provided with regreasing arrangement, keep the grease outlet open and fill grease when the motor is running so that old grease/excess grease will flow out.

- ❖ Balmer Lawrie LL3 and Shell-MP 3 are recommended for use in motors. Mixing of grease should be avoided.
- ❖ When the motor is opened, protect bearings from foreign particles and dirt by wrapping them with clean paper or polythene sheet.
- ❖ During reassembly of motor ensure that wavy washer and brass washers are kept in their position and bearing covers are secured properly. These washers are specially designed to provide adequate preloading on the bearings.
- ❖ Clean the entire path of the cooling air on the motor at regular intervals.
- ❖ The temperature of the motor, judged by hand feeling, could be misleading. In the case of suspected overheating the actual temperature should be measured with thermometer and should be compared with the permissible temperature rise according to the temperature class of the motor.
- ❖ Overheating of the motor may be due to over loading of motor, too low or too high supply voltages, frequency fluctuations, over greasing of bearings, foreign material in the air gap between stator and rotor. Necessary corrective action is to be taken accordingly.
- ❖ When ordering spare parts state the motor type, machine number, type of construction as shown in the rating plate, part description given in the part list and number of units required.

► Special installation instructions for IP55/IP56 construction motors :

- ❖ Conduit entries are fitted with threaded plugs and are sealed. Open the plug and clean threads before fitting cable gland. Use double compression gland and seal the threads of glands with sealing cement. This will ensure IP55/IP56 Protection of the cable entry.
- ❖ After the cable connection fix the T. Box properly. Ensure that the rubber gasket provided is not dislocated or distorted and fixing screws are fully tightened.
- ❖ Wherever possible it is recommended to cover the motor from direct heating by the sun. Provide a canopy over the motor.
- ❖ The motor shaft is provided with oil seals/ 'v' rings on both ends. Drain plugs are provided on front and back sides.(ref. fig 2.) During periodic inspection say once in 3 months open the drain plugs and drain out condensed water if any.
- ❖ While replacing oil seals make sure that oil seals are not distorted, the springs are in their position and the lip of the oil seal is free. Apply small amount of grease to the lip. 'V' rings can be replaced by first removing the M.S. cap. the new 'v' ring is to be fitted such that the lip just rests against the end shield face. (Excessive pressure will lead to premature failure of the 'v' ring). Replace the M.S.cap.
- ❖ Whenever, the motor is opened and reassembled ensure that all joints faces are properly cleaned and gasket cement is applied properly at all joints.(ref. fig 2.)
- ❖ Recommended gasket cements : Anabond 681 of Anabond Ltd.

2: SPECIAL INSTRUCTIONS FOR INSTALLATION AND MAINTENANCE OF FLAME-PROOF MOTORS :

A sealing end box is mandatory for all motors for use for Gas Gr. I and Oil Mines.

A DGMS identification mark must be fitted on the motor for use for Gas Gr. I or Oil Mines. In case the DGMS mark is not provided please obtain the same from BBL.

- ❖ Flame-proof motor is designed and manufactured in accordance with the requirements of IS 2148-1981. The construction is approved by C.M. R.I. No modification or alteration to be approved construction of the motor is permitted. For replacement of parts, please consult Bharat Bijlee.
- ❖ Each motor must be protected by a motor protections circuit breaker or any other protective device approved by the concerned authorities.
- ❖ The cable entry can be made from any one of four directions by turning the terminal box in steps of 90° C. Do not turn the bottom piece. Lead wires will be damaged if bottom piece is turned.
- ❖ Conduits and type of cable (e.g. PVC, PILCDWA, ect.) should strictly correspond to the conduit tapping or cable entry provided on the terminal box.
- ❖ For PVC cables when sealing box is not provided, use FLP cable glands. Statutory approval is a must for FLP glands.
- ❖ For PVC cables, when sealing box is provided use of SIBG glands is permitted.
- ❖ For PILCDWA cables (used in mines), the cable entry consists of sealing box, adaptor plate, cable gland with lead bush and a cable clamp. When assembled make sure that the cable is held firmly in the gland.
- ❖ Before supply cable connection, Sealing box (where ever used) should be properly filled with solid setting bituminous compound specified for electrical purpose. Compound Retaining Barrier is provided in between the Terminal Box and Sealing Box. Drill required size of holes on it and replace/fix carefully such that supply cables can pass through for making terminal connections before compound filling.
- ❖ Strip off the insulation properly from the cable ends. The position where the cable insulation is cut should be carefully taped before making the connections.
- ❖ Connections of supply leads to the motor terminals should be made as shown in the connection diagram. The clearances and creepage distance inside the terminal box must be maintained to the maximum.
- ❖ During assembly of terminal box parts and subsequent routine maintenance, please observe the following points.
- ❖ The machined joint faces shall not be refinished, tampered, damaged or coated with varnish or paint.
- ❖ On all motor a thin coat of Grease should be applied on all motor joints. (Grease Balmer Lawrie LL3 should be used)
- ❖ Replace defective/broken screws by new screws of the original material and tensile strength as per grade 8.8.
- ❖ All screws, bolts, nuts etc. used for fixing the parts of flame-proof enclosure are to be provided with spring washers to prevent them from getting loose due to shocks and vibrations, during operation.
- ❖ All gaps between mating parts of joints forming flame-proof enclosure are to be thoroughly checked with feeler gauge to ensure that gap clearances are within 0.1mm.

■ Dismantling and reassembling.**Follow the sequence given below :**

- ❖ Remove the fan cowl and fan, unscrew fixing screws of back endshield and pull out the back endshield with the rotor in the case of MJ80 to MJ130. In other motors unscrew the front B.B.C.(where ever provided) fixing screws also before pulling out the back endshield with the rotor. Pull out front endshield after unscrewing the fixing screws.

- ❖ Press out the back endshield in the case of MJ80 to MJ130 after removing the circlip on the inside of endshield bearing housing.. In other frame sizes back endshield can be removed from rotor after removing back outer B.B.cover.
- v Dismantling of the motor should be done carefully without damaging any of the joint faces components rotor, stator and windings. If any damage is noticed after dismantling, such component should be replaced by the new component. Rectification of damage by metal filling or adhesive filling is not permitted.
- v Assembly of the motor is to be done in reverse order of dismantling .
- v During rewinding take precautions given below.
- v Burning of old winding to remove coils from slot should not be done.
- v Cut overhang portion of winding with chisel.
- v Heat the body at 130°-140° C in the oven for 2 hrs.
- v With the help of copper rod and hammer, force out copper wire from the slots and clean slots by filing.
- v Stator body should be handled carefully to avoid damage on machined portion of the body. Any damage, burr will result in change of flame path gap.
- v Reassembled motor carefully as explained above.

N.B.:

- 1) Burning of winding with flame will distort the body. After reassembly flame path gap may increase.
- 2) Carefull handling and correct reassembly shall ensure flame-proofness of the enclosure.
- 3) It is advisable to give rewinding work to an authorised rewinder of BBL.

3: SPECIAL INSTRUCTIONS FOR INSTALLATION AND MAINTENANCE OF BRAKE MOTORS :
IMPORTANT :

Before giving supply to the motor ensure that the brake is releasing. Apply the specified voltage at the brake terminals, and check that the motor rotates freely by turning the shaft by hand.

In case the brake is not releasing, adjust the air-gap between the magnet assembly and the armature disk assembly to 0.3 mm as described below.

ADJUSTMENT OF AIRGAP/ COMPENSATION FOR LINER WEAR :

The wear of the brake liner depends on the frequency of operation or number of starts/stops of the motor and the load GD2 or inertia of the load .

It is recommended that the airgap (ref. fig.5 & 6) should generally be done when the liner is worn out through 1 mm. thickness (i.e. total air gap is 1.3 mm)

METHOD :

Remove the fan cowl.

In case of motors in frame size 71 & 80 remove the split pin (400) from the castlenut(ref.fig. 5).

In case of motors in frame size 90 to 132, remove the screws (402) from the rubber cover (ref. fig. 2).

❖ Remove the rubber cover (ref. fig. 2).

❖ Now rotate the castlenut/lockknut till the air gap is 0.3 mm. Use filler-gauge to ensure proper air gap.

❖ Insert the split pin or fix the screws in the castlenut/locknut as the case may be.

❖ Replace the rubber cover in its place and fix the fan cowl. The brake is now adjusted and ready for operation.

It is recommended that the entire armature disk assembly is replaced when the liner has worn by 3 to 4 mm. (i.e. after 3 or 4 adjustments).

Adjusting the braking torque :

The braking torque is proportional to the number of compression springs. The standard torque values for different frame sizes are given below :

Frame sizes	Std.Braking torque (Kgm)
71	0.5
80	1.0
90S, 90L	2.0
100L	4.0
112M	5.0
132S, 132M	5.0

It can be increased by upto 40% (max). by inserting washers under all the compression springs, after removing the castle nut/lock nut and fan.

It can also be reduced by upto 50% (max). by removing some of the compression springs. Not more than half of them should be removed. the remaining springs must be distributed uniformly around the circumference of the magnet yoke.

The brake should be then reassembled.

SPARES :

The list of spares which can be provided is given in fig. 5 and 6. A manual release kit is available for incorporating manual release arrangement for motors in 90S onwards.

N.B:

- 1.0 Brake unit with Manual Release arrangement cannot be replaced in old design for 132S/132M Frame Brake motors.
- 2.0 Brake unit with manual release arrangement can be replaced in old design of 90S/90L, 100L & 112M Frame.

4 : SPECIAL INSTRUCTIONS FOR INSTALLATION AND MAINTENANCE OF SLIP RING MOTORS.
TERMINAL BOX:

The terminal box is arranged on top of the frame. It contains 6 terminals (3 for stator, 3 for rotor). The terminal box conforms to degree of protection IP55.

The terminal box is provided with two twin-cable entries. One twin entry is on Righthand side and the other on the Left-hand side as viewed from the driving shaft end.

Two earthing terminals are provided in the terminal box and one on the mounting foot.

Cable entry size is 3/4" B.S. conduit entry. Maximum cable OD suitable for these entries is 19mm Dia.

SLIP RINGS, BRUSH-BLOCK ASSEMBLY:

The Slip-rings are arranged at the drive end. These are easily accessible by removing the top T.Box cover.

The brush holders are assembled as a complete unit called brush-block assembly. It can be easily replaced as a whole without dismantling the motor.

BEARING:

Pre-published Sealed for Life Deep-Groove ball bearings are used on the motors.

STARTING:

The starting torque is increased by introducing external resistance in the rotor circuit. The maximum starting torque that can be achieved is equal to the Break-down(Pull-out) torque.

The starting resistance (including rotor resistance) $R + r$ (In ohms) is calculated from the equation-

$$R+r = \frac{U}{I_n \times \sqrt{3}} \times \frac{M_n}{M_a}$$

Where, R = external resistance per phase

r = rotor resistance per phase

I_n = rotor rated current

U = rotor Voltage

M_n = rated torque, 'kg-m'

M_a = required starting torque, 'kg-m'

In most cases, the rotor resistance is neglected and $R+r$ is assumed equal to the external starting resistance. Should it be necessary to allow rotor resistance, it can be determined with sufficient accuracy from the following equation-

$$r = \frac{U}{I_n \times \sqrt{3}} \times \frac{N_s - n}{N_s}$$

Where N_s = Synchronous speed

n = Rated speed

As the speed picks up, the starter cuts-out the external resistance in steps. The various values for $R+r$ are calculated by assigning different values to M_a while using the equation.

SPARES :

The following items are available as spares (in addition to items shown in fig. 3.)

1. Brush holder
2. Slip Ring
3. Carbon Brushes

5 : Fault Analysis

TROUBLE	CAUSE	REMEDY
1) Abnormal noise (a) Continuous	i) Fan rubbing against end shield ii) Fan rubbing against cowl, dented iii) Bearing failure iv) oil seal rubbing v) Rotor-Stator rubbing vi) Excess preloading of bearing	i) Rectify the defect ii) Replace cowl/rectify iii) Replace bearing iv) Apply few drops of oil to lip v) Rectify the defect vi) Reduce preloading
(b) Intermittent	i) Dirt in bearing greases	i) Clean & regrease bearings (ref: 6-II)
2) Magnetic noise	i) air gap not uniform ii) Rotor unbalance	i) check & correct endshield fit/bearing ii) Re-balance rotor
3) No Load current is high	i) Wrong external connections ii) Voltage high iii) Frquency low iv) Faulty installation v) Inherent design feature vi) Stator - rotor misalignment	i) Verify & correct ii) - iii) - iv) Correct v) * vi) Verifty & correct
<p>* Note : a) In case of small hp, special motors, Crane duty motors, the no Load current could be as high as Full Load current.</p> <p>b) No Load current specified in Test Certificate is at rated voltage i.e. generally 415 V 50 Hz.</p> <p>If No load current is high check for Voltage & Freq. variation.</p>		
4) Full Load current is high	i) Voltage high/low ii) Motor selection is wrong iii) Overloading iv) Blowers/pumps operating out of specified range	i) Regulate supply ii) Select correct motor iii) Take coorrective action iv) Operate in specified range
5) No laod Current unbalance	i) Wrong external Correction ii) Voltage unbalance iii) Stator winding resistance unbalance	i) Verify & Correct ii) Check for faulty leads connections and transformer iii) Rewind
<p>Note : There could be current unbalance of 5% (15% for 2 pole) on No load running even with balanced volatge supply. The unbalance in current reduces when the motor is loaded.</p> <p>1% unbalance in voltage can cause 6 to 10% u.balance in current</p>		

TROUBLE	CAUSE	REMEDY
6) Hot bearings, ball or roller	i) Insufficient grease ii) Deterioration or contamination of grease iii) Excess grease iv) Overloaded bearings v) Broken ball/rough races	i) Maintain proper grease quantity. ii) Remove old grease, wash bearing thoroughly in petrol to which a few drops of oil have been added & replace with new grease. iii) Reduce grease quantity iv) Take corrective action v) Replace bearing & clean housing.
7) Shaft temp. is high	i) Defective bearing ii) Oil sealing rubbing against shaft (in motors with oil seal)	i) Replace bearing ii) 45°C-50°C rise above ambient is OK. If more replace oil seal or put drop of oil on the lip.
8) Motor body temp is high (Check at eyebolt hole with thermometer)	i) Rotor - stator rubbing ii) Wrong motor selection iii) Overloading iv) Ambient temp. is high v) Inherent design feature (B/F class) vi) Fan cooling is affected vii) High no. of start/stops viii) Motor dirty ix) Single phasing x) Voltage unbalanced	i) Rectify ii) Select correct motor iii) Reduce load/change motor design. iv) Select right motor v) No action required if temp. rise is within limits vi) Rectify vii) Verify the motor selection viii) Clean periodically xi) Check lead connections x) Check for faulty leads connections and transformers
9) Speed is low	i) Frequency low ii) Defective rotor iii) Overloading	i) - ii) Replace motor iii) Take corrective action
10) Wrong direction rotation.	i) Wrong sequence of phases	i) Interchange any 2 phases
11) Motor runs and then stops	i) Power failure/Single phasing iii) Overload	i) Check for loose connections iii) Examine over load relay trip setting
12) Motor connected but does not start	i) No supply voltage, one phase open or voltage too low ii) Starting torque of load too high iii) Control great defective	i) Check voltage on each phase. ii) Reduce load or study requirement. If sq. cage motor with auto-transformer starting, change to a higher tap. If slipping, lower starting resistances. iii) Rectify (Check contacts)

TROUBLE	CAUSE	REMEDY
13) Motors do not take load	<ul style="list-style-type: none"> i) Defective motor ii) Wrong motor selection iii) Voltage low 	<ul style="list-style-type: none"> i) Replace motor ii) Change the motor iii) -
14) (a) Water/oil/ Dirt entry	<ul style="list-style-type: none"> i) Oil seal defective ii) Improper mounting of oil seal iii) Poor joint sealing 	<ul style="list-style-type: none"> i) Replace oil seal ii) Replace oil seal iii) Rectify
(b) Oil leakage from gear box	<ul style="list-style-type: none"> i) Flange fixing holes are not tightened/ sealed. 	<ul style="list-style-type: none"> i) Rectify
15) Vibration	<ul style="list-style-type: none"> i) Defective bearings ii) Rotor-rubbing iii) Motor misalignment iv) Loose fixing bolt v) Poor balancing of drive equipment vi) Coupling out of balance vii) B a l a n c i n g weights detached viii) Wound rotor coils replaced ix) Weak foundation x) Single phasing xi) Excessive end play add washer 	<ul style="list-style-type: none"> i) Replace bearings ii) Rectify iii) Re-alignment iv) Rectify v) Rebalance vi) Balance coupling vii) Rebalance rotor viii) Rebalance rotor ix) Strengthen base x) Check for single phasing xi) Replace bearing or add washer under D.E. bearing
16) Motor fails or burns	<ul style="list-style-type: none"> i) Defective bearings ii) Voltage unbalance overheating iii) Loss of insulation of stators wdg. iv) Overloading v) Ambient temp. is high vi) Winding failure (inter-tum short, failure of lead wire, insulation paper, etc) 	<ul style="list-style-type: none"> i) Replace bearing ii) - iii) Rewind-provide space heater if humidity is high. iv) Take corrective action v) Rewind with higher insulation class vi) Rewind.
17) Bearing failure	<ul style="list-style-type: none"> i) Defective bearings ii) Overloading (in the case of belt drive, use roller bearing) iii) Poor alignment iv) Poor/No lubrication v) Dried out greases 	<ul style="list-style-type: none"> i) Replace bearing ii) Take corrective action iii) Correct misalignment iv) Lubricate v) Regrease
18) Rusting of shaft/ flange	<ul style="list-style-type: none"> i) Poor application of rust preventive ii) Long/wrong storage of Motor 	<ul style="list-style-type: none"> i) Clean shaft/flange ii) Clean shaft/flange

TROUBLE	CAUSE	REMEDY
19) Axial Play	<ul style="list-style-type: none"> i) Bearing preloading washer misplaced ii) Wrong application of motor iii) NDE End Shield bearing housing damaged. 	<ul style="list-style-type: none"> i) Replace preloading washer ii) Select the correct motor iii) Replace End Shield
20) Overload relay tripping due to excess current	<ul style="list-style-type: none"> i) Overloading ii) Starting time is high iii) Defective rotor iv) Wrong selection of motor v) High voltage variation vi) Low Frequency vii) Wrong relay setting (Due to variation in voltage & frequency the current drawn will be higher. If relay setting is on full load current as per name plate relay may trip.) 	<ul style="list-style-type: none"> i) Take corrective action ii) Take corrective action iii) Replace motor iv) Change the motor v) Contact the manufacturer vi) Reduce loading if possible vii) Set relay at 1.15 times full load current
21) Thermal relay	<ul style="list-style-type: none"> i) Design of motor not matching application ii) Wrong selection of thermistor for the application/motor 	<ul style="list-style-type: none"> i) Contact manufacturer ii) Replace with correct thermistor
22) Seizing of shaft on FLP motor	<ul style="list-style-type: none"> i) Excessive belt load ii) Bearing failure iii) Inner BBC loosely fitted 	<ul style="list-style-type: none"> i) Reduce belt load ii) Re-assemble after rectifying damage iii) Fixing screws of Bearing covers should be tightened properly during reassembly
23) Low Insulation	<ul style="list-style-type: none"> i) Motor subject to water, rains, floods. 	<ul style="list-style-type: none"> i) Dismantle and clean parts. Then bake windings in oven at 90° C for 24 hours or until resistance to ground is sufficient (> 1 megaohm)
<div style="border: 1px solid black; padding: 5px; width: fit-content; margin: 0 auto;"> <p>Note: 1) Also refer IS 900 - 1992. 2) In case of difficulty in locating the cause for a problem please contact nearest branch office of Bharat Bijlee Ltd.</p> </div>		

6. RECOMMENDED MAINTENANCE SCHEDULE :**▶ Daily Maintenance :**

- ❖ Examine visually earth connections and motor leads.
- ❖ Check motor windings for overheating.
- ❖ Examine control equipments.

▶ Weekly Maintenance :

- ❖ Check belt tension. In cases where this is excessive, it should immediately be reduced .
- ❖ Blow out the motor surface of protected type motors situated in dusty locations.
- ❖ Examine starting equipment for burnt contacts where motor is started and stopped frequently.

▶ Monthly Maintenance

- ❖ Overhaul controllers.
- ❖ Inspect and clean oil circuit breakers.
- ❖ Wipe brush holders and check bedding of brushes of slip- ring motors.

Half Yearly Maintenance :

- ❖ Clean windings of motors subjected to corrosive or other elements; also varnish and bake, if necessary.
- ❖ In case of slip-ring motors, check slip-ring for grooving or unusual wear.
- ❖ Check grease in ball and roller bearings and make it up where necessary, taking care to avoid over-filling.

Note : 1) Where regreasing provision is given, regreasing should be done while the motor is running. Keep the grease outlet open.

2) The grease used by Bharat Bijlee is Balmer Lawrie LL3. Mixing of grease of other make/type should be avoided.

▶ Annual Maintenance :

- ❖ Check all high speed bearings and renew, if necessary.
- ❖ Blow out all motor surface thoroughly with clean dry air. Make sure that the pressure is not so high as to damage the insulation.
- ❖ Clean and varnish dirty and oily windings.
- ❖ Overhaul motors which have been subjected to severe operating conditions.
- ❖ Renew switch and fuse contacts, if damaged.
- ❖ Renew oil in starters subjected to damp/corrosive elements.
- ❖ Check insulation resistance to earth and between phases of motor windings, control gear and wiring.
- ❖ Check resistance of earth connections.
- ❖ Test the motor overload relays and breakers.

▶ Records :

- ❖ Maintain a register giving one or more pages for each motor and record therein all important inspection and maintenance works carried out from time to time. These records should show past performance, normal insulation level, air gap measurements, nature of repairs and time between previous repairs and other important information which would be of help for good performance and maintenance.

(FIG. 2)

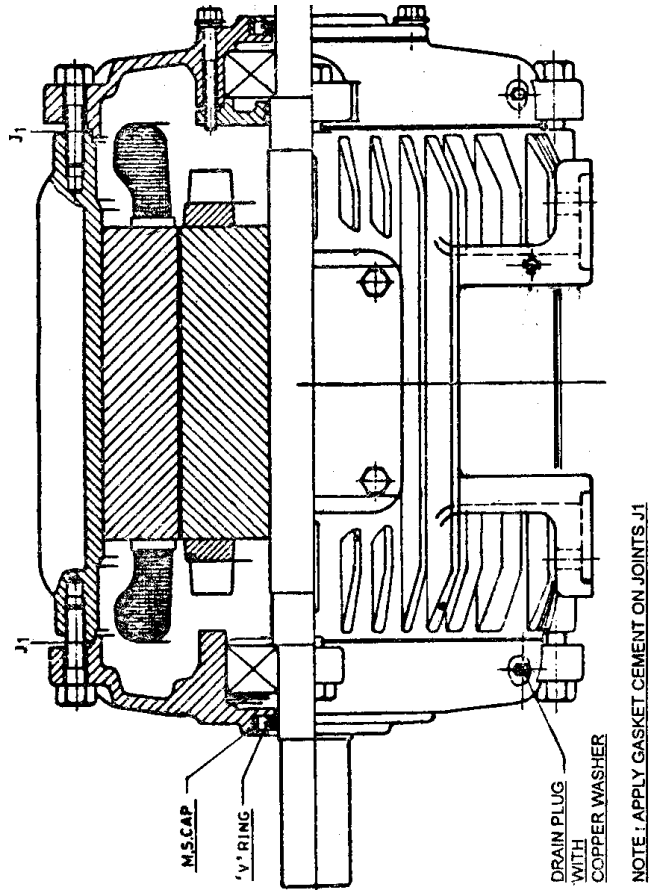

(FIG. 1)

- 1) Stud (High Tensile Stud)
- 2) Disc (M.S.)
- 3) Nut (M.S.)

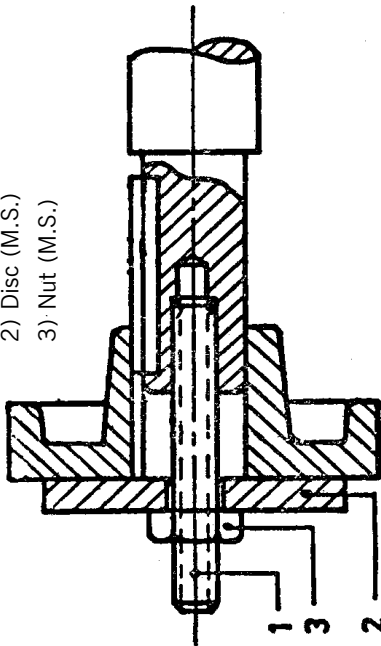



STANDARD MOTOR SPARE PARTS IDENTIFICATION (FIG. 3)

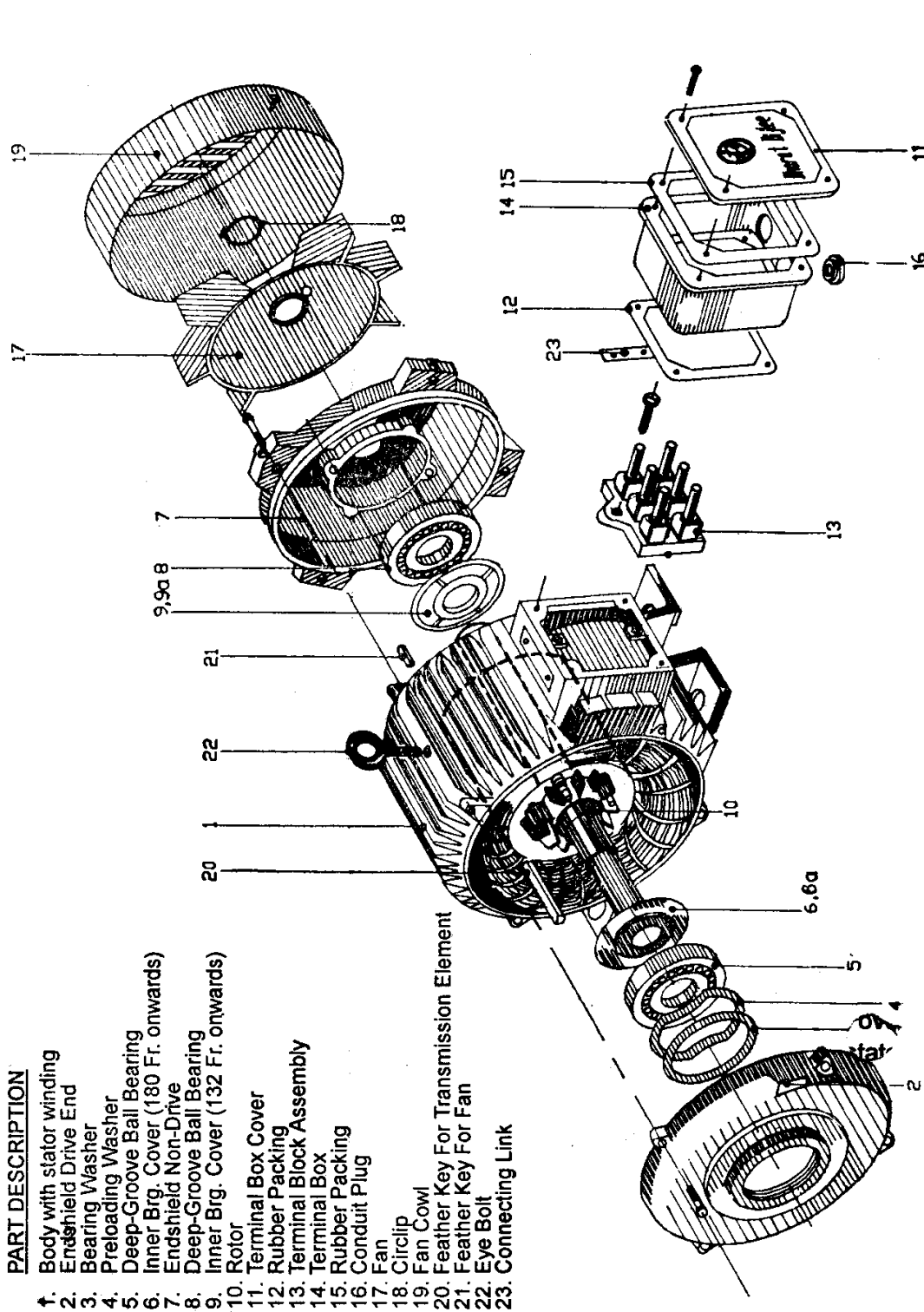



FLAME PROOF MOTORS SPARE PARTS IDENTIFICATION

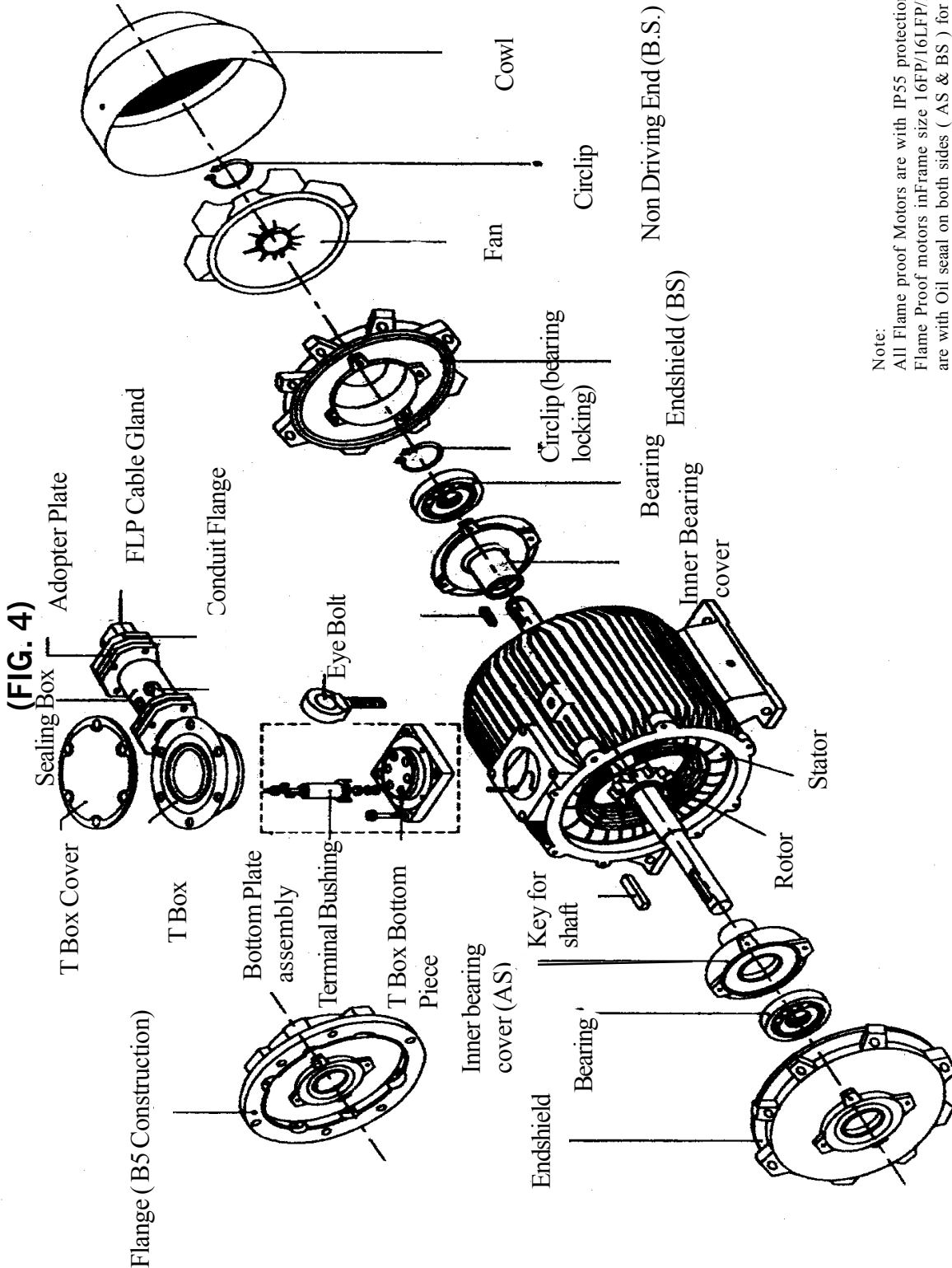

Note:
 All Flame proof Motors are with IP55 protection
 Flame Proof motors inFrame size 16FP/16LFP/MJ180/20LFP/60FP/MJ280 are with Oil seal on both sides (AS & BS) for IP55 protection.

Flame proof motors MJ80,MJ90,MJ130,MJ160,MJ200,MJ225, and MJ250 are provided with Rubber seal ' V ring' and M.S.Cap on both sides (AS & BS) for IP55 protection.

Flame proof motors with B5 construction are provided with Oil seal on Driving side (AS) for O.T.S.

Driving End (A.S.)

Non Driving End (B.S.)

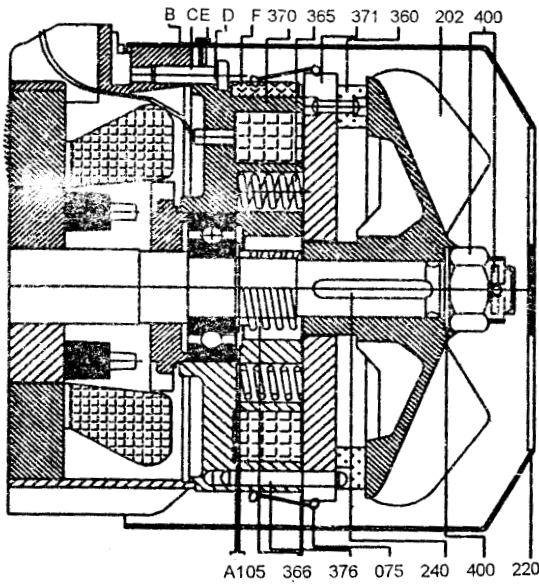

- 1) WORKING AIR GAP 61-0.4 MM TO BE ADJUSTED WITH THREADED LOCK NUT
- 2) BRAKE LINER SURFACE OF ARMATURE AND BRAKE SURFACE OF FAN SHOULD BE CLEAN
- 3) FAN BORE, SHAFT AND THREAD SURFACE ARE TO BE TREATED WITH RUST PREVENTIVE

MANUAL RELEASE SPARES

- 075) COVER SLEEVE FOR MAGNET
- 105) BUSH M.S.
- 202) FAN C.I.
- 220) FAN COWL
- 240) FEATHER KEY FOR FAN
- 360) BRAKE LINER
- 365) SPRING FOR FAN
- 366) SPRING FOR FAN
- 370) MAGNET ASSEMBLY
- 371) ARMATURE DISC ASSEMBLY
- 376) GUIDE PIN
- 400) CASTLE NUT, WASHER AND SPLIT PIN

THE ABOVE ITEMS ARE AVAILABLE AS SPARES

- A) CIRCLIP (EXTERNAL)
- B) SPRING WASHER
- C) HEX. HEAD SCREW
- D) SPRING WASHER
- E) CHEESE HEAD SCREW
- F) PACKING

FIG. 5
FRAMES 71 & 80

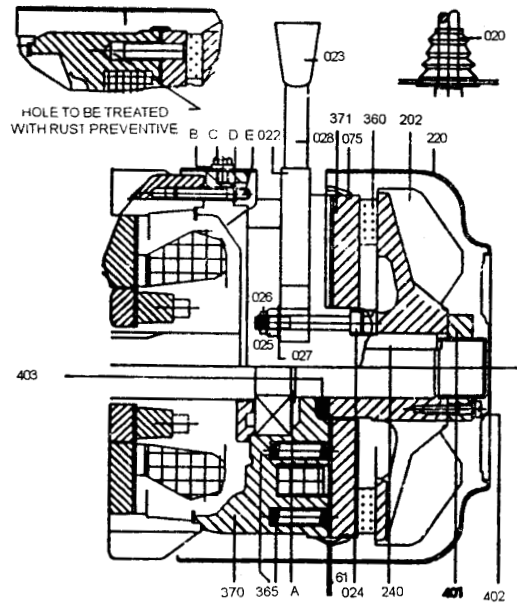

075) COVER SLEEVE FOR MAGNET

- 105) BUSH M.S.
- 202) FAN C.I.
- 220) FAN COWL
- 240) FEATHER KEY FOR FAN
- 360) BRAKE LINER
- 365) SPRING FOR BRAKING
- 366) SPRING FOR FAN
- 370) MAGNET ASSEMBLY
- 371) ARMATURE DISC ASSEMBLY
- 376) GUIDE PIN
- 400) CASTLE NUT, WASHER AND SPLIT PIN
- 401) LOCK NUT, WASHER
- 402) LOCK NUT FIXING SCREW
- 403) V.RING

MANUAL RELEASE SPARES

- 020) RUBBER BELLOWS
- 022) BRACKET
- 023) KNOB
- 024) BRACKET SCREW
- 025) SLOTTED NUT
- 026) SPLIT PIN
- 027) PLAIN WASHER
- 028) M.S. ROD

THE ABOVE ITEMS ARE AVAILABLE AS SPARES

- A) CIRCLIP (EXTERNAL)
- B) SPRING WASHER
- C) HEX. HEAD SCREW
- D) SPRING WASHER
- E) CHEESE HEAD SCREW

FIG. 6
FRAMES 90 TO 132

: Registered Office :

Electric Mansion, 6th Floor, Appasaheb Marathe Marg, Prabhadevi, Mumbai 400 025.
Tel.: 2430 6237, 2430 6375 Fax: 022-2437 0624

: Central Marketing Office & Works :

Post Box No. 100, Thane Belapur Road, Thane 400 601.
Tel : 2760 0401 / 2760 0411 Fax : 91-22-2760 0430

Offices

REGION	CITY	ADDRESS	PHONE	FAX
NORTH	NEW DELHI	Milap Niketan, 4th floor 8A, Bahadur Shah Zafar Marg, New Delhi 110 002.	2371 14 34 2331 96 94 /95/96	011-2331 9413
	LUDHIANA	7, Gian Market, Opp. Ramgarhia Gurudwara, G. T. Road, Miller Ganj, Ludhiana - 141 003.	2531 663 2542 131	0161-2533826
	INDORE	C/o. Tirupati Engineering, 128, 3rd Floor, Dawa Bazar, RNT Marg, Indore 452 001.	2704 474 2704 486	0731-2704390
EAST	KOLKATA	Flat No.8, 'Mansarowar', 2nd Floor, 3B Camac Street, Kolkata 700 016.	2217 23 82 2217 23 83/ 84	033-2217 2467
WEST	MUMBAI	Post Box No.100, Thane-Belapur Road, Thane 400 601.	2760 58 34 2760 58 35 / 36	022-2760 0430
	PUNE	9, Ketki Building, 2nd Floor, Next to Alka Theatre, Sadashiv Peth, Pune 411 630.	433 48 31 432 12 67	020-433 9210
	AHMEDABAD	202, Arth, 8-Rashmi Society, Behind A. K.Patel House, Mithakhali, Cross Road, Ahmedabad - 380 009.	2642 76 67 2643 08 98	079-2656 3581
SOUTH	BANGALORE	204-207, Ramanashree Chambers, 2nd Floor, No.37, Lady Curzon Road, Bangalore 560 001.	559 26 81 559 21 37 559 62 74	080-559 2823
	CHENNAI	C/o. Arpan Corporation, AVM Studios Compound, 38, Arcol Road, Vadapalani, Chennai 600 026.	2372 85 79 2472 67 34	044-2372 8579
	SECUNDERABAD	Krishna Mansion, 2nd Floor, Adjacent to Bible House, 134, Rashtrapati Road, Secunderabad 500 003.	2753 45 12	040-2753 1791